

Main Board

 StarFive 赛昉科技		
Title		
JH7110 EVB		
Size	Document Number	Rev
B	02:Diagram-MainIO	V10
Date:	Tuesday, August 22, 2023	Sheet 2 of 16

+5V

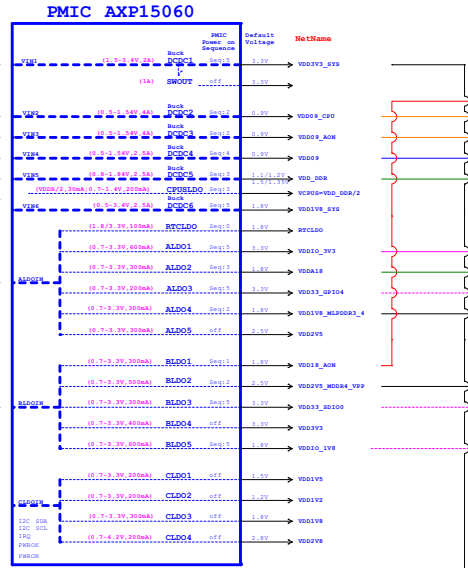

Core Board

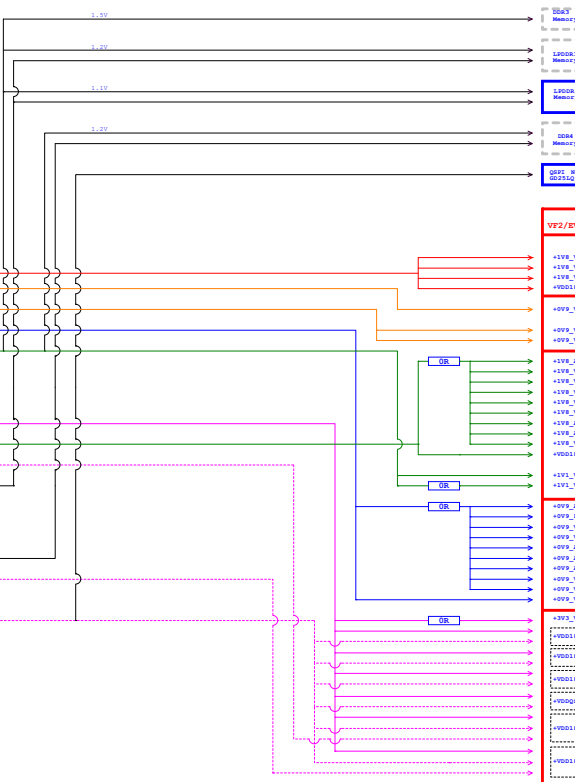
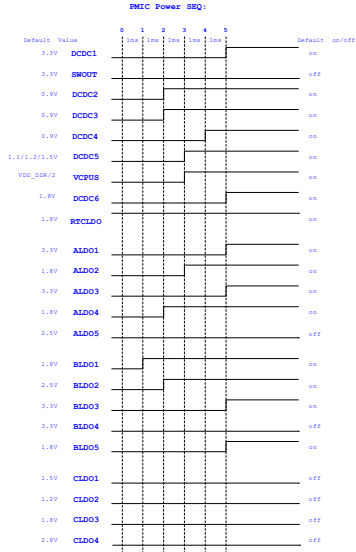

V12/EVB NoName	Ball Name	Recommended Merge Net	JH7110 Seq
+V18_VDD18_AON	VDD18_AON	VDD18_AON	[Timing Diagram]
+V18_VDD18_MON	VDD18_MON	VDD18_MON	[Timing Diagram]
+V18_VDD18_TEMP	VDD18_TEMP	VDD18_TEMP	[Timing Diagram]
+V18_VDD18_SSB	VDD18_SSB	VDD18_SSB	[Timing Diagram]
+V09_VDD09_AON	VDD09_AON	VDD09_AON	[Timing Diagram]
+V09_VDD09_MON	VDD09_MON	VDD09_MON	[Timing Diagram]
+V09_VDD09_TEMP	VDD09_TEMP	VDD09_TEMP	[Timing Diagram]
+V09_VDD09_SSB	VDD09_SSB	VDD09_SSB	[Timing Diagram]
+V09_VDDI01833_AON	VDDI01833_AON	VDDI01833_AON	[Timing Diagram]
+V09_VDDI01833_MON	VDDI01833_MON	VDDI01833_MON	[Timing Diagram]
+V09_VDDI01833_TEMP	VDDI01833_TEMP	VDDI01833_TEMP	[Timing Diagram]
+V09_VDDI01833_SSB	VDDI01833_SSB	VDDI01833_SSB	[Timing Diagram]
+V09_VDD09	VDD09	VDD09	[Timing Diagram]
+V09_VDDI01833	VDDI01833	VDDI01833	[Timing Diagram]
+V09_VDD09	VDD09	VDD09	[Timing Diagram]
+V09_VDDI01833	VDDI01833	VDDI01833	[Timing Diagram]
+V09_VDD09	VDD09	VDD09	[Timing Diagram]
+V09_VDDI01833	VDDI01833	VDDI01833	[Timing Diagram]
+V09_VDD09	VDD09	VDD09	[Timing Diagram]
+V09_VDDI01833	VDDI01833	VDDI01833	[Timing Diagram]
+V09_VDD09	VDD09	VDD09	[Timing Diagram]
+V09_VDDI01833	VDDI01833	VDDI01833	[Timing Diagram]
+V09_VDD09	VDD09	VDD09	[Timing Diagram]
+V09_VDDI01833	VDDI01833	VDDI01833	[Timing Diagram]

Note:  
 1: SEQ1\_4 always enable 0.9V1000 support 3.3V/3.0V.  
 2: IF B010 support 2nd boot, use 0.9V alpha should follow from 0.9V12, 1.2V01833-0.9V14.  
 3: IF B010 support 0.9V12 and 0.9V10, 0.9V12 Power should link to VDD09\_CFU and 0.9V10 to Power should link to VDD09\_MON04.  
 4: B0101\_12 0.9V12 Power is optional.  
 5: IF B010 support 0.9V12, 0.9V10, 0.9V12 0.9V10 to Power should link to VDD09\_CFU and 0.9V10 to Power should link to VDD09\_MON04.  
 6: B0101\_12 0.9V12 Power is optional.  
 7: VDD09\_V3 or VDD09\_V18 can be used Power Source for other applications.  
 8: Sometimes Data Power from-behavior to protect 0.9V10 Power.

VDD09	DCDC3 Configuration for JH7110 G0374 and L0306V1 10			
	DCS5P			
	D0S3	D0S4	D0S5	Floating
	1.8V(8+0)	0.9V(8+0)	0.9V(8+0)	0.9V(8+0)
	1.8V	1.2V	1.2V	1.2V

**PAGE LIST**

PAGE01: Diagram-Core Sys  
 PAGE02: Diagram-MainIO  
 PAGE03: Diagram PD  
 PAGE04: Diagram-GPIOs List  
 PAGE05: History  
 PAGE06: JH7110 Power  
 PAGE07: JH7110 DDR Ctrl  
 PAGE08: JH7110 GMAC0&1  
 PAGE09: JH7110 EMMC&QSPI  
 PAGE10: JH7110 GPIOs  
 PAGE11: JH7110 HIFs  
 PAGE12: JH7110 SYS&OSC&TEMP  
 PAGE13: DDR4 RAM  
 PAGE14: eMMC Flash  
 PAGE15: SOM Interface  
 PAGE16: PMIC Power

**JH7110 GPIO List**

Power Group	GPIO Name	Default FUN	Core Devices	Main Devices	Notes	
VDD1833_GPIO3	GPIO00					
	GPIO01					
	GPIO02					
	GPIO03					
	GPIO04					
	GPIO05					
VDD1833_GPIO4	GPIO06					
	GPIO07					
	GPIO08					
	GPIO09					
	GPIO10					
	GPIO11					
	GPIO12					
	GPIO13					
	GPIO14					
	GPIO15					
	GPIO16					
	GPIO17					
	GPIO18					
	GPIO19	PMIC_SCR/E2FROM_SCR		U10 & U14		
GPIO20	PMIC_SDA/E2FROM_SDA		U10 & U14			
VDD1833_GPIO1	GPIO21	DDR Type/Size Config				
	GPIO22	DDR Type/Size Config				
	GPIO23	DDR Type/Size Config				
	GPIO24	DDR Type/Size Config				
	GPIO25					
	GPIO26					
	GPIO27					
	GPIO28					
	GPIO29					
	GPIO30					
	GPIO31					
	GPIO32					
	GPIO33					
	GPIO34					
	GPIO35					
VDD1833_GPIO2	GPIO36					
	GPIO37					
	GPIO38					
	GPIO39					
	GPIO40					
	GPIO41					
	GPIO42					
	GPIO43					
	GPIO44					
	GPIO45					
	GPIO46					
	GPIO47					
	GPIO48					
	GPIO49					
	GPIO50					
	GPIO51					
	GPIO52					
	GPIO53					
	GPIO54					
	GPIO55					
GPIO56						
GPIO57						
GPIO58						
GPIO59						
GPIO60						
GPIO61						
GPIO62	SDMMC_RST_N		U7			
GPIO63						
VDD18_AON	RGPIO0	Boot Mode				
	RGPIO1	Boot Mode				
	RGPIO2	Boot Mode				

**Note1:**All 64GPIOs support full mux,Please refer to relevant detailed documents.

**Note2:**"- - - - - << NetName" or "NetName <<- ->" is only used to indicate the connection between pages.



StarFive  
赛昉科技

Title: JH7110 EVB

Size: B	Document Number: 04:Diagram GPIOs List	Rev: V10
Date: Tuesday, August 22, 2023	Sheet: 4	of: 16

JH7110\_DEVKIT\_DDR4\_CORE\_L6\_V20

V11 20230701 update to V20 20230726 :

1.Update JH7110 reset circuits on page16;



Title		
JH7110 EVB		
Size	Document Number	Rev
B	05:History	V10
Date:	Tuesday, August 22, 2023	Sheet 5 of 16

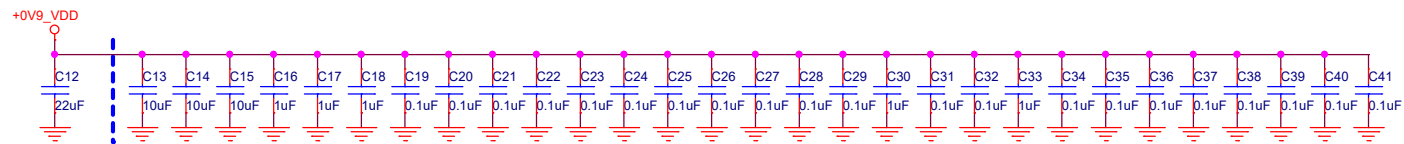
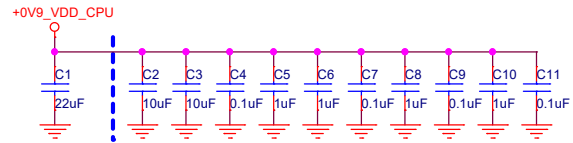
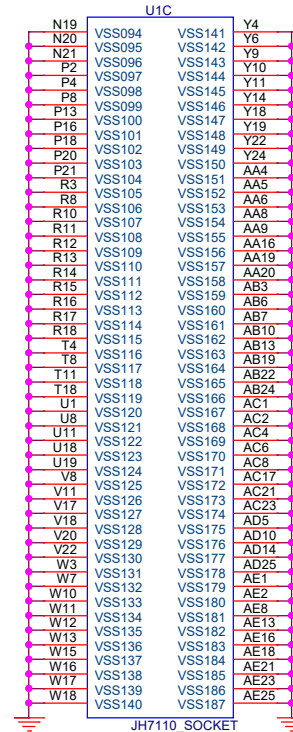
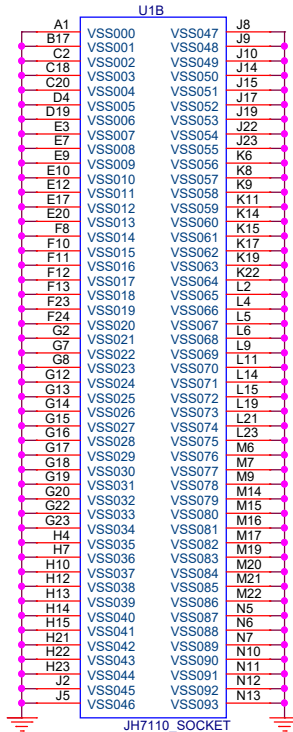
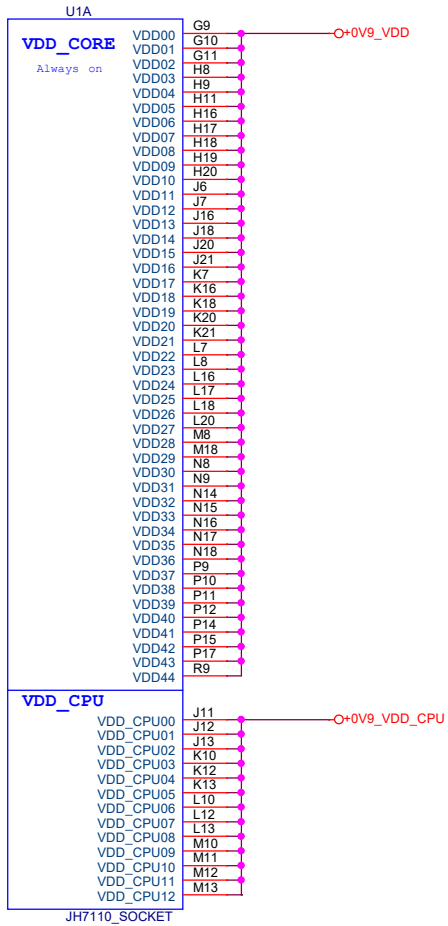

**StarFive**  
赛昉科技

Title: **JH7110 EVB**

Size: <b>B</b>	Document Number: <b>06:JH7110 Power</b>	Rev: <b>V10</b>
Date: <b>Tuesday, August 22, 2023</b>	Sheet: <b>6</b>	of <b>16</b>

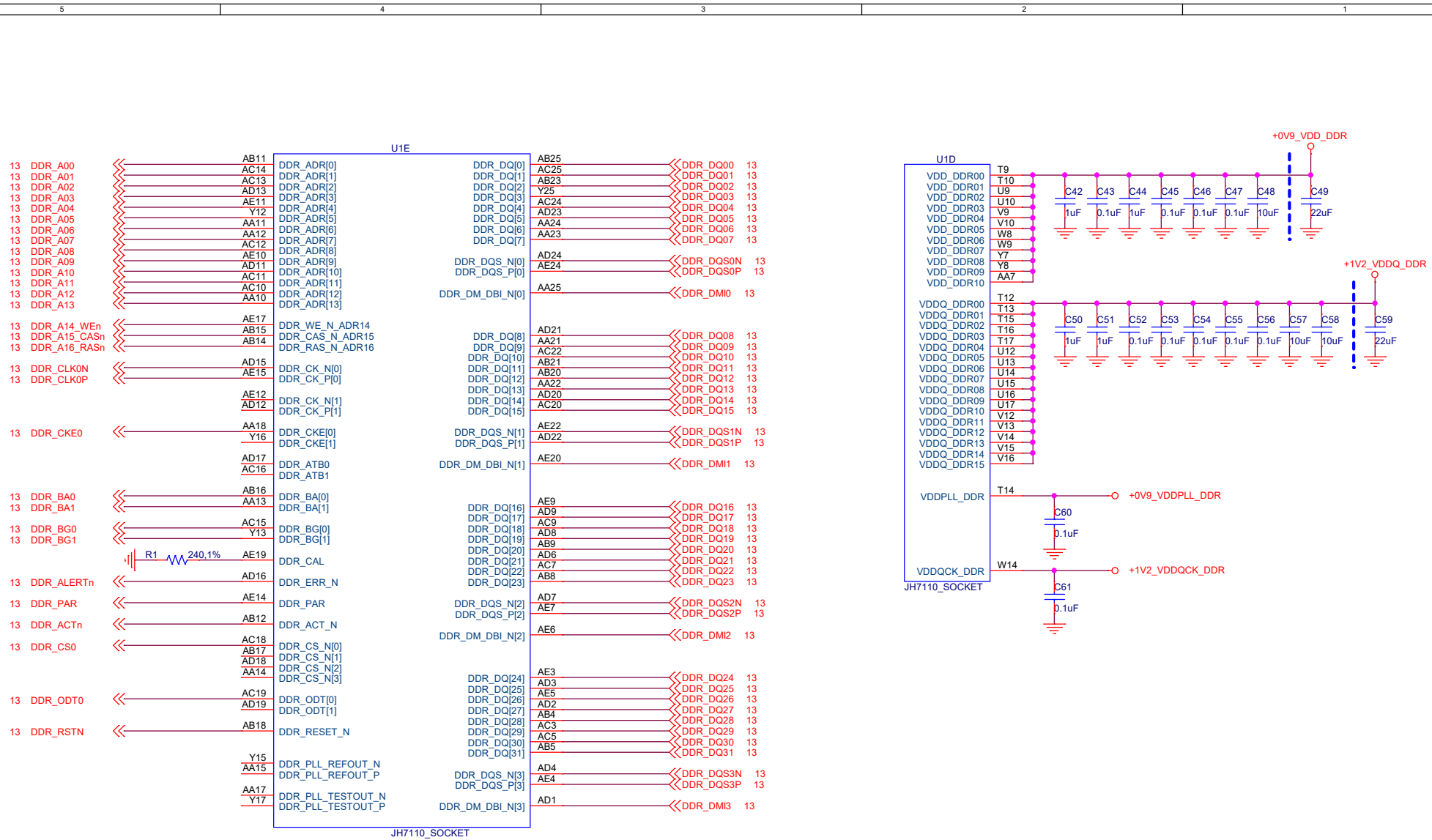

Title		
JH7110 EVB		
Size	Document Number	Rev
B	07:JH7110 DDR Ctrl	V10
Date:	Tuesday, August 22, 2023	Sheet 7 of 16

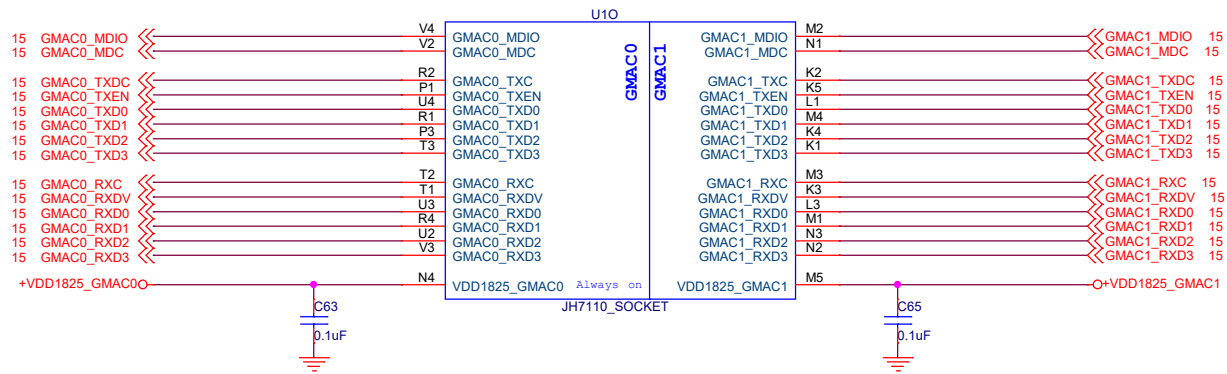



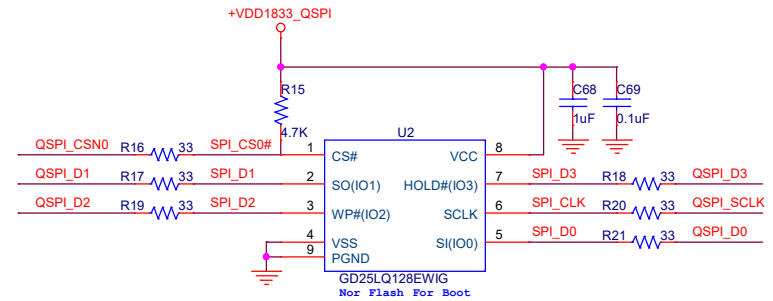
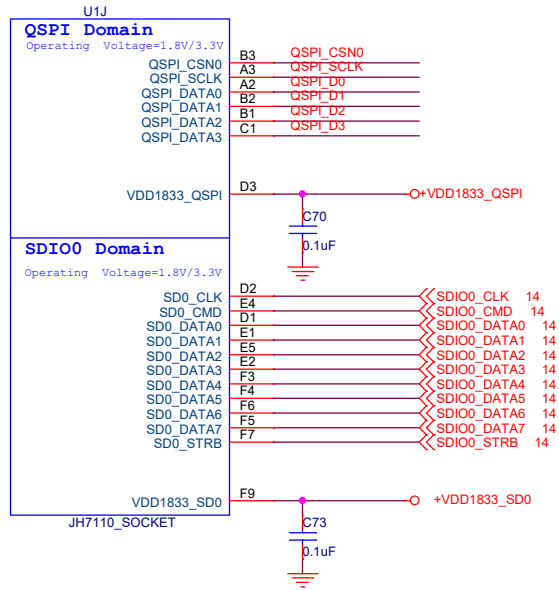

QSPI_SEL_VDD1833	VDD1833_QSPI
Low: 0	3.3V
High: 1	1.8V



Title		
JH7110 EVB		
Size	Document Number	Rev
B	09:JH7110 EMMC&QSPI	V10
Date:	Tuesday, August 22, 2023	Sheet 9 of 16

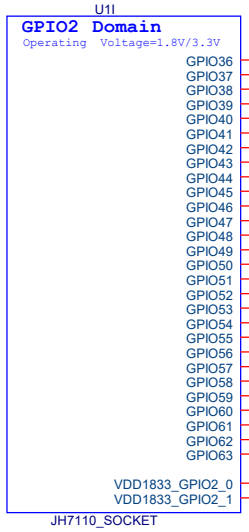
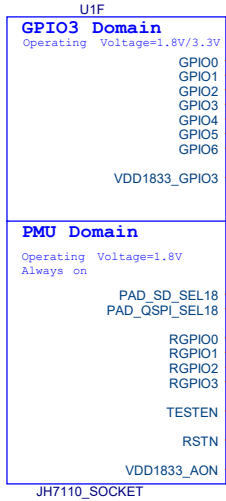

RGPI01	RGPI00	Boot Mode
0	0	QSPI Flash
0	1	SD Card
1	0	eMMC
1	1	UART

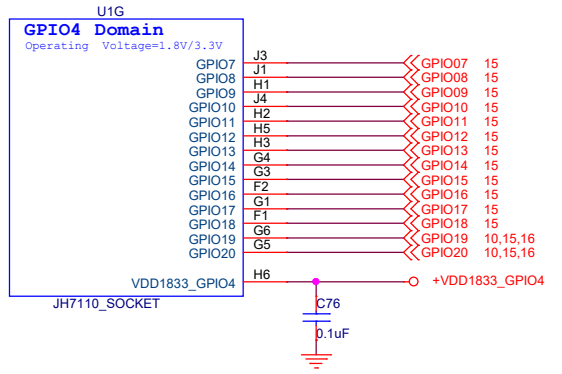
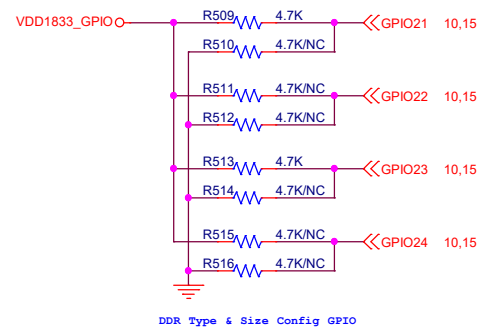
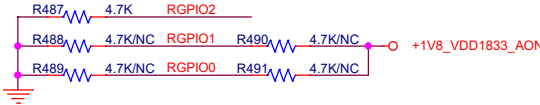

DDR Type	GPIO24,23		GPIO22,21	
	GPIO24,23	GPIO22,21	GPIO24,23	GPIO22,21
LPDDR4	0	0	0 0 +8GB	0 1 +4GB
	1	0	1 0 +2GB	1 1 +1GB
	1	1	1 1 +TBD	1 1 +TBD
DDR4	0	1	0 0 +32Gb*2	0 1 +16Gb*2
	1	0	1 0 +8Gb*2	1 1 +4Gb*2

DDR Type	GPIO24,23		GPIO22,21	
	GPIO24,23	GPIO22,21	GPIO24,23	GPIO22,21
LPDDR3	1	0	0 0 +4GB	0 1 +2GB
	1	1	1 0 +1GB	1 1 +TBD
	1	1	1 1 +TBD	1 1 +TBD
DDR3	1	1	0 0 +8Gb*2	0 1 +4Gb*2
	1	1	1 0 +2Gb*2	1 1 +1Gb*2

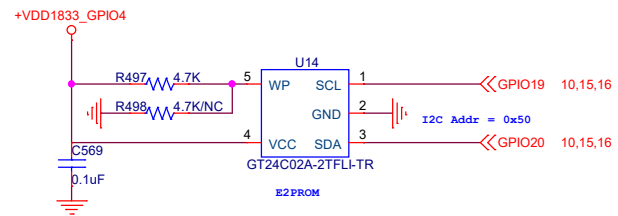
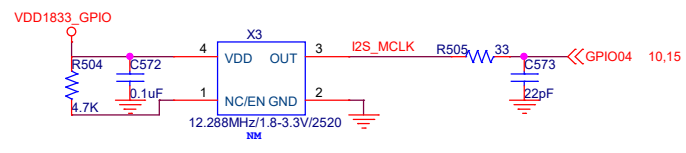
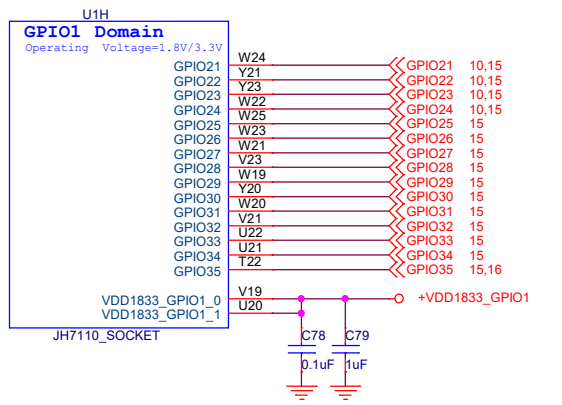

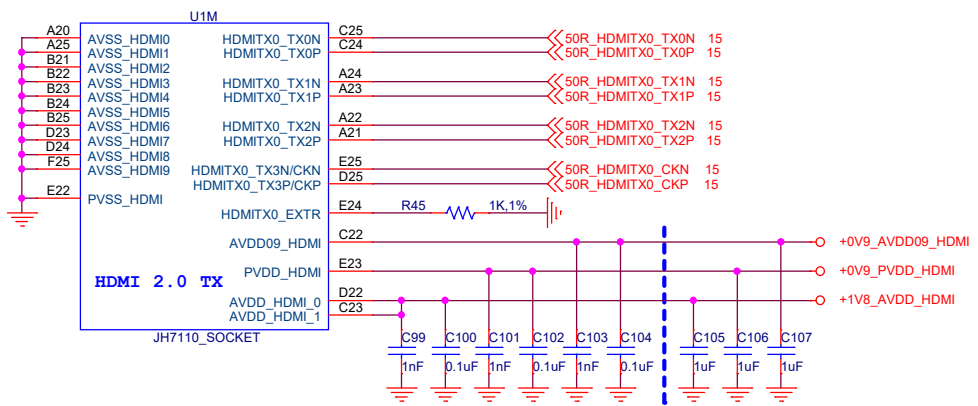
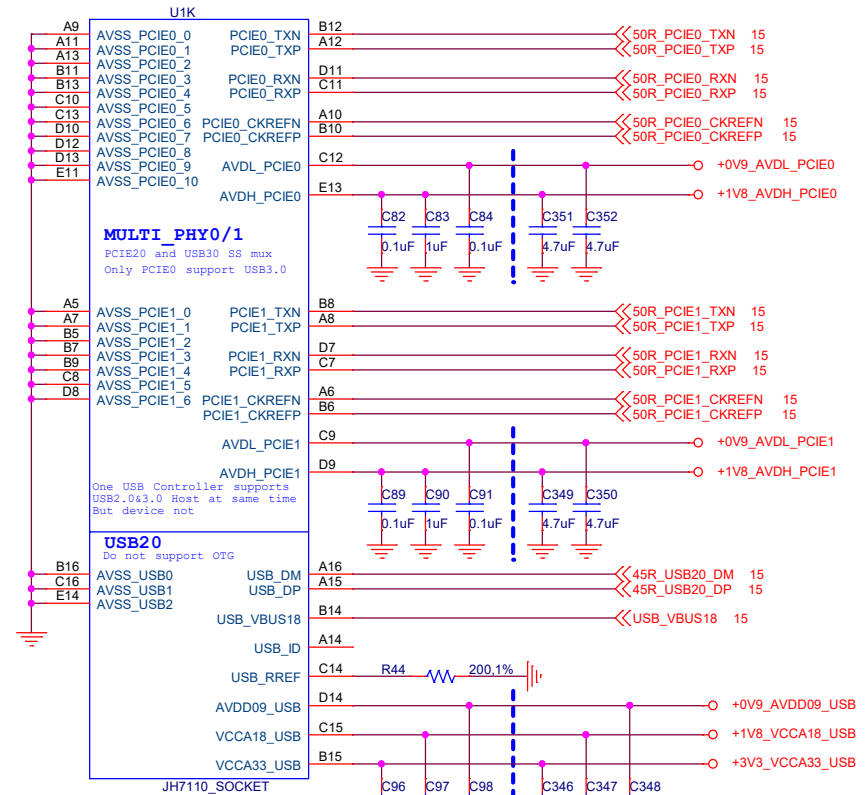
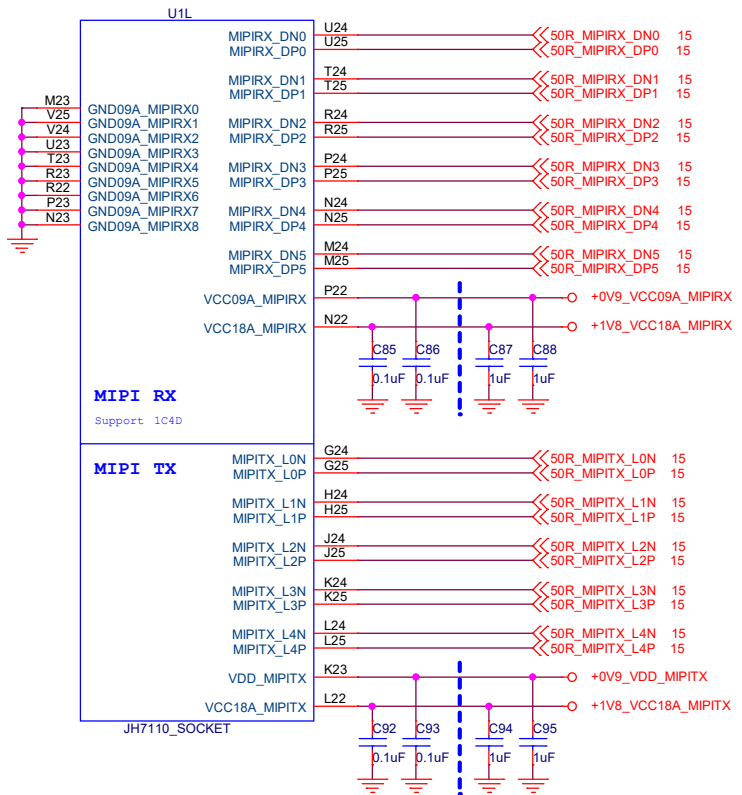

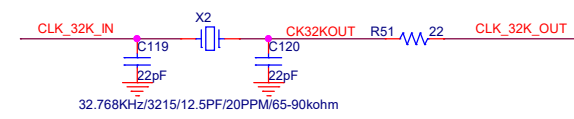
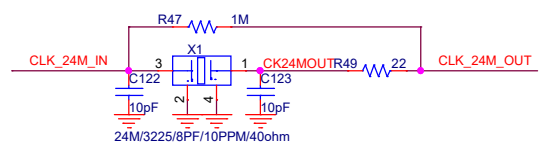
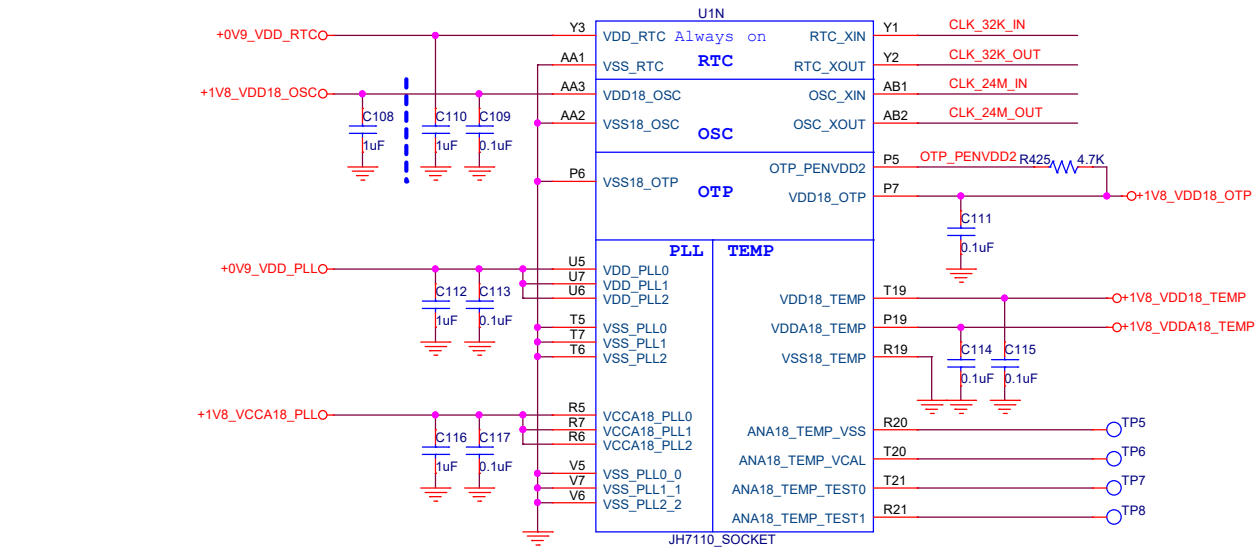

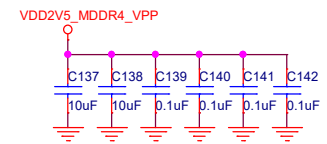
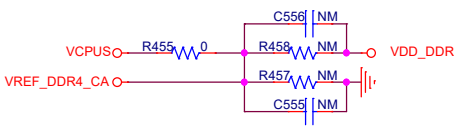
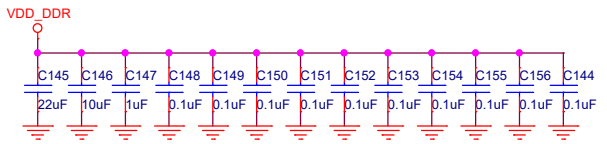
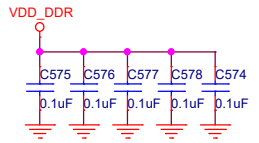
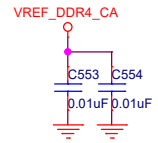
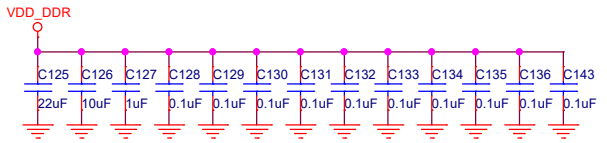
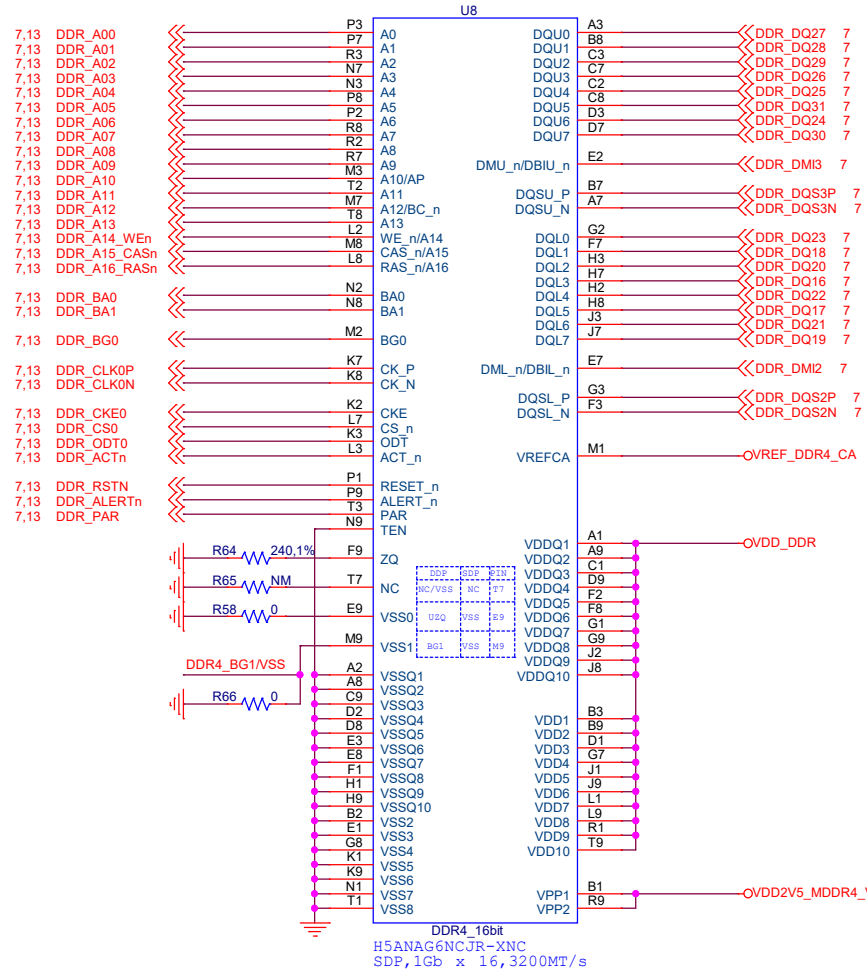
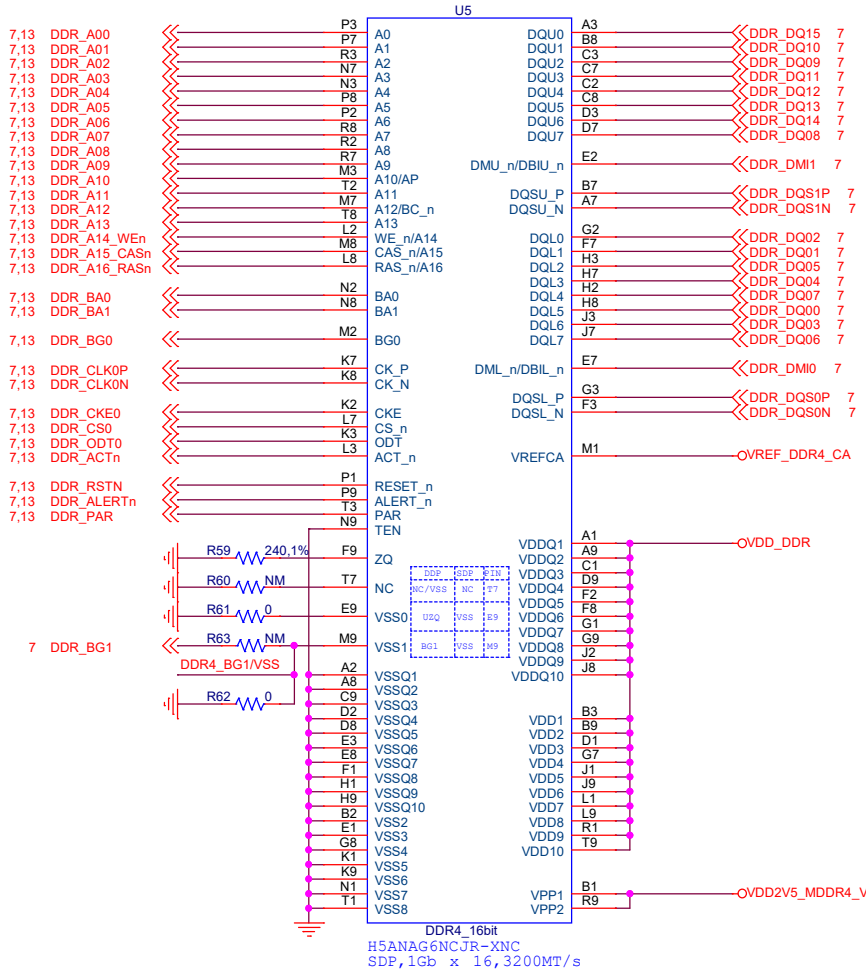

StarFive 赛昉科技

Title: JH7110 EVB

Size: B	Document Number: 13:DDR4 RAM	Rev: V10
Date: Tuesday, August 22, 2023	Sheet: 13 of 16	

eMMC Reset Solution:

Default Normal: +VDD1833\_SD0 or +VDD1833\_GPIO2 = 3.3/1.8V  
R196=NC;R208=NC;C234=NC;U15=ON;Q2=NC;R506=NC

CostDown1: +VDD1833\_SD0 = +VDD1833\_GPIO2 = 1.8V/3.3V  
R196=NC;R208=33;C234=NC;U15=NC;Q2=NC;R506=NC

CostDown2: +VDD1833\_SD0 = 1.8V & +VDD1833\_GPIO2 = 3.3V  
R196=NC;R208=4.7K;C234=5.6K;U15=NC;Q2=NC;R506=NC

CostDown3: +VDD1833\_SD0 = 3.3V & +VDD1833\_GPIO2 = 1.8V  
R196=4.7K;R208=NC;C234=NC;U15=NC;Q2=ON;R506=4.7K

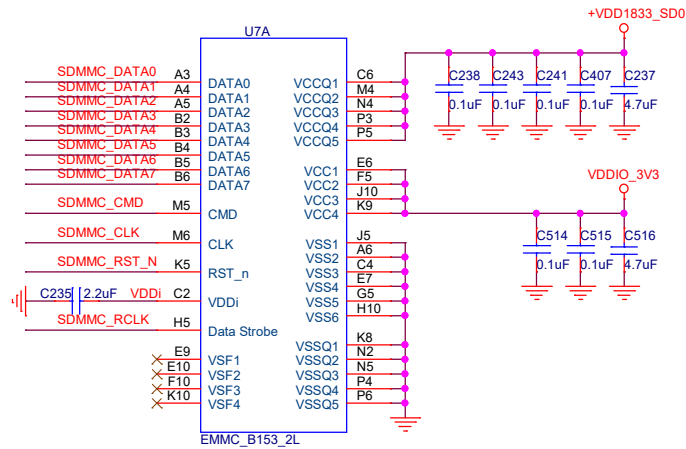
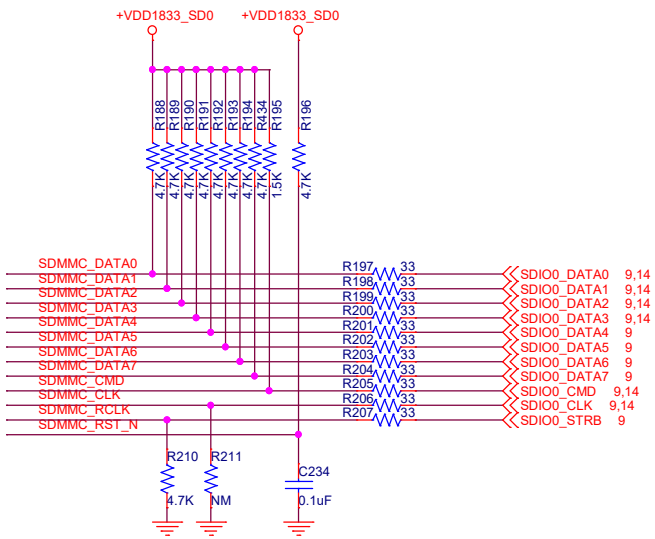
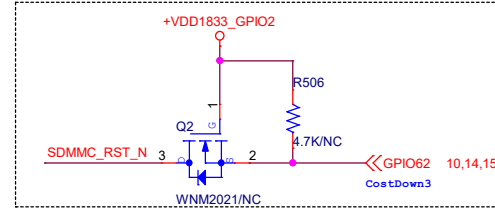
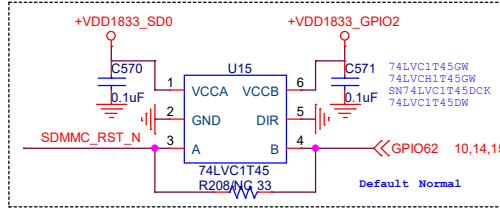

SD_SEL_VDD1833	VDD1833_SD0
Low:0	3.3V
High:1	1.8V

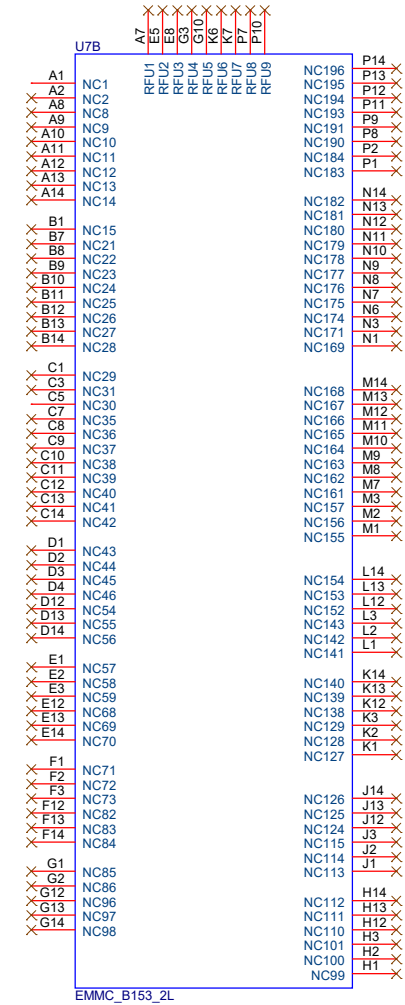
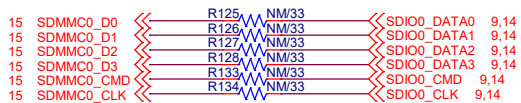
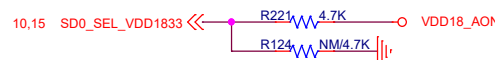

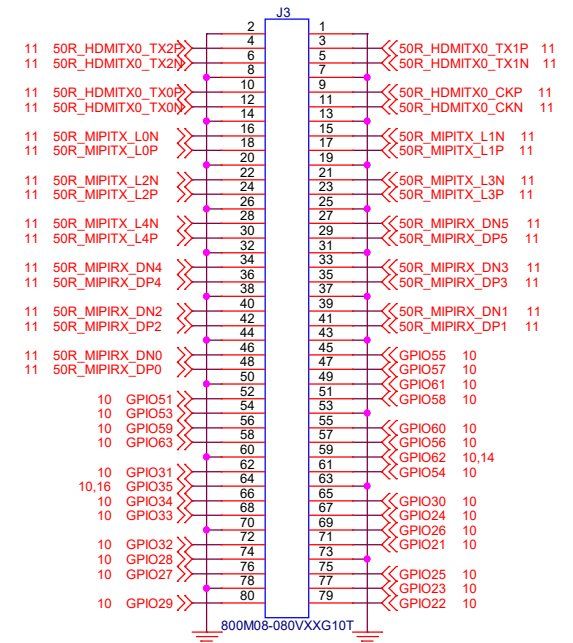
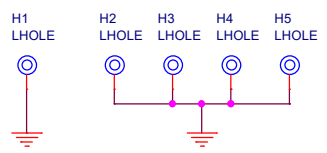
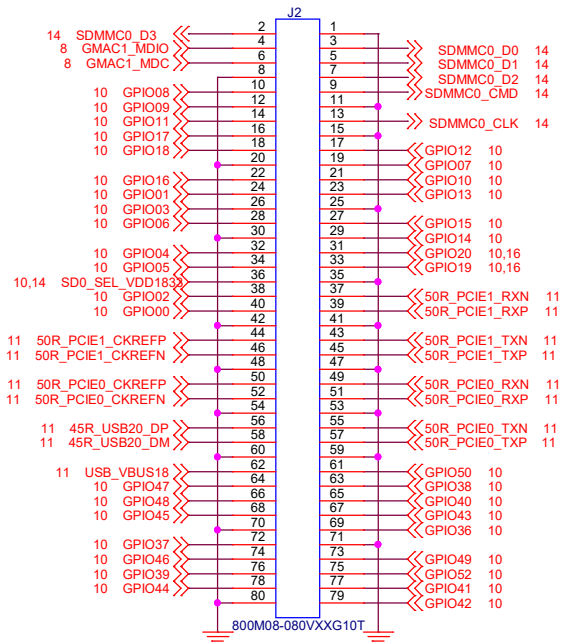
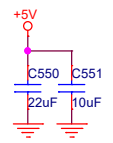
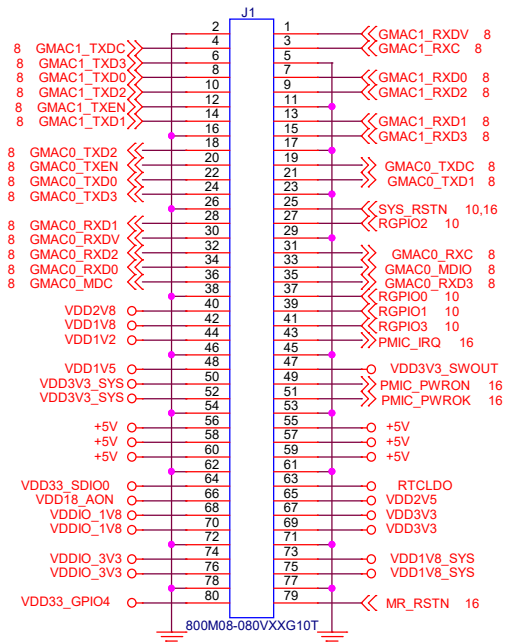

 <b>StarFive</b> 赛昉科技		
Title: <b>JH7110 EVB</b>		
Size: <b>B</b>	Document Number: <b>17:SOM Interface</b>	Rev: <b>V10</b>
Date: <b>Tuesday, August 22, 2023</b>	Sheet: <b>15</b> of <b>16</b>	

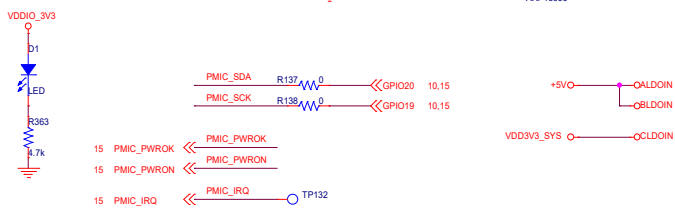
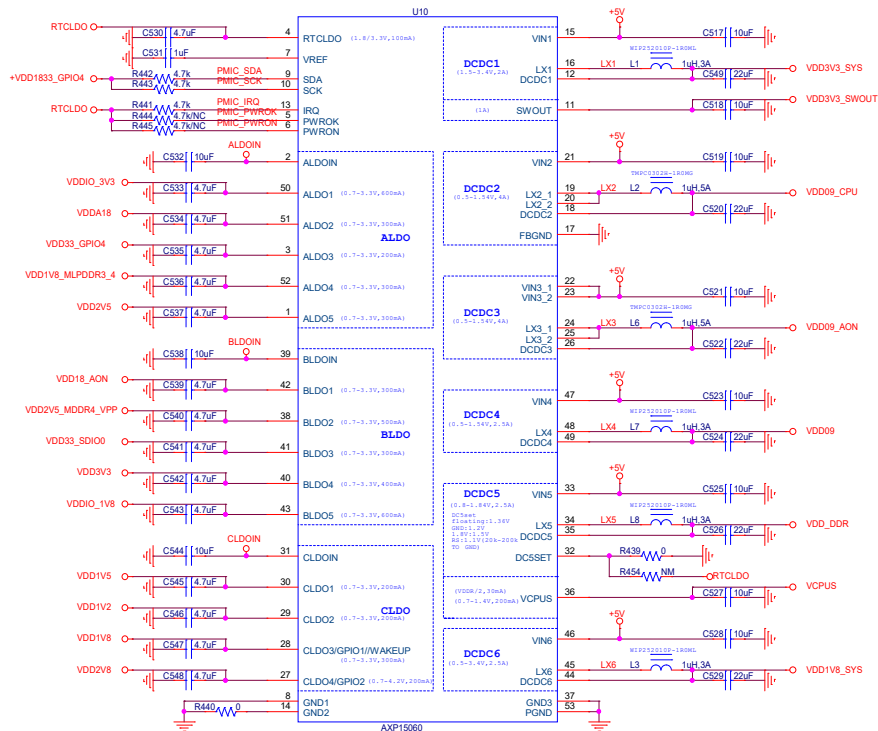

### Timing 1



### Timing 2



### Timing 3

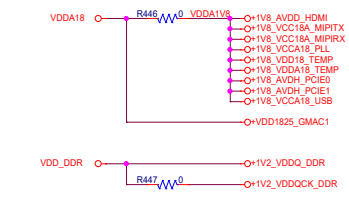

### Timing 4

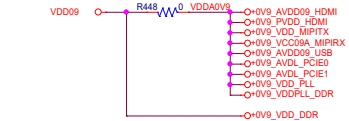

### Timing 5

